

# Specifications & Technical Data\*

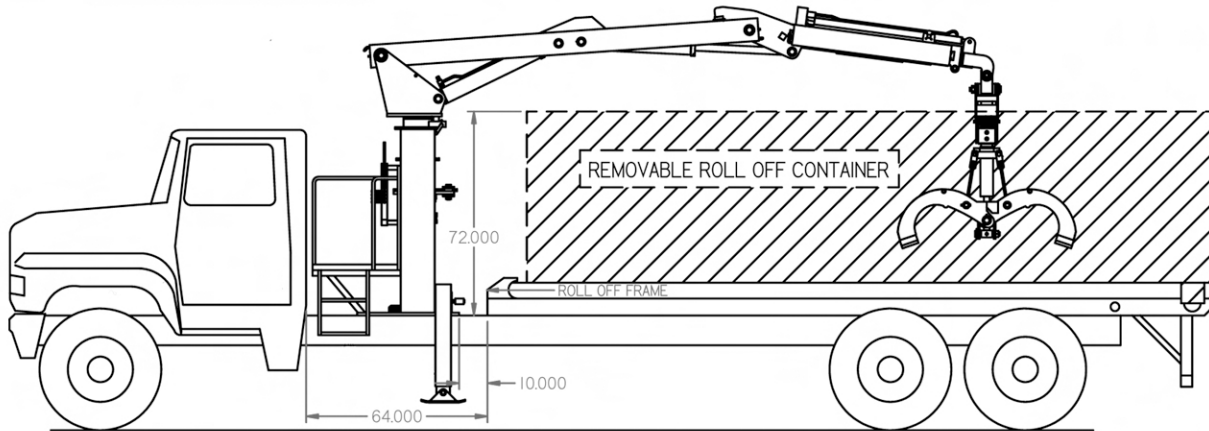

## NOTES

1. MAXIMUM DISTANCE FROM THE GROUND TO THE TOP OF CAB IS 10'-1".
2. MINIMUM DISTANCE FROM THE BACK OF CHASSIS CAB TO THE FRONT OF ROLL OFF FRAME IS 5'-4".
3. MAXIMUM CONTAINER HEIGHT IS 6'-0", MEASURED FROM THE TOP OF CHASSIS FRAME TO THE TOP OF CONTAINER HEAD BOARD.

## System Description

Petersen Model BL-3 loader is mounted to chassis between the cab and the cable rolloff hoist, which is mounted on a long wheelbase cab chassis. The loader operates from a fixed platform located behind the truck cab. All hydraulic components for the loader system are provided.

## General

Reach (from centerline rotation)	20ft
Main Boom and Tip Boom	16ft
Tip Extension	4ft
Unit Weight (Empty)	5,685lbs
Outrigger Span	11ft 8in
Storage Height (above frame)	8ft 4in

## Lifting Capacities

10ft	7,100lbs	Weight of bucket and/or attachments must be subtracted from lift capacities
16ft	4,400lbs	shown. Standard bucket weighs appx. 1000lbs. Capacities shown do not exceed
20ft	3,200lbs	85% of vehicle tipping moment with outriggers fully extended on firm, level ground.

## Bucket Features

The bucket is 4ft long with an opened width of 5ft between pickup blades. Anti-scalping bucket sides are pivot mounted to provide a horizontal closing action rather than a vertical digging motion. Sides are mechanically linked to single hydraulic cylinder to ensure that both sides close and open together. No hydraulic hoses below bucket rotator.

## Recommended Chassis Specification (Minimum)

Gross Vehicle Weight Rating	60,000lbs
Cab-to-Rolloff Dimension	62in
Frame RBM	1,500,000

Actual rolloff unit, estimated loads, and container length dictates the selection of the chassis.

## Operator Controls

Dual manual controls (greaseless) for outriggers and loader on both sides of the truck for easy access and visibility. Also available with "QuadStick" dual joystick controls. Stationary top-mount control seat is optional.

## Structural

A-frame pedestal design allows flexing under repeated load shocks. Replaceable Cast Nylon bushings used in head assembly. Head assembly is stress relieved. Reinforced connection points with hardened pins and replaceable bushings. Counterbalance valves used on boom cylinders and pilot operated check valves used on vertical outrigger cylinders.

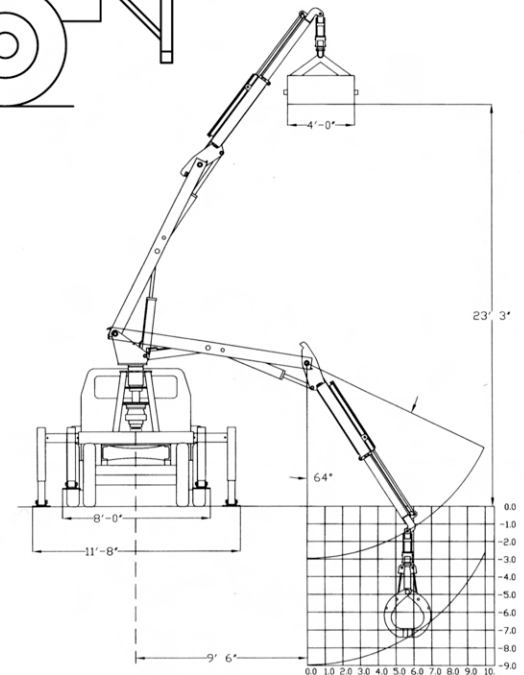

Petersen Industries, Inc.

Your Authorized Dealer is:

**Municipal Equipment Sales, Inc.**

Mailing Address: PO Box 1233  
Location: 208 Bell Place  
Woodstock, GA 30188

Local: 770-928-0424  
Fax: 770-928-7512  
Nationwide Toll Free: 1-800-782-2243  
Email: sales@municipalequipment.com  
Web: www.municipalequipment.com

